

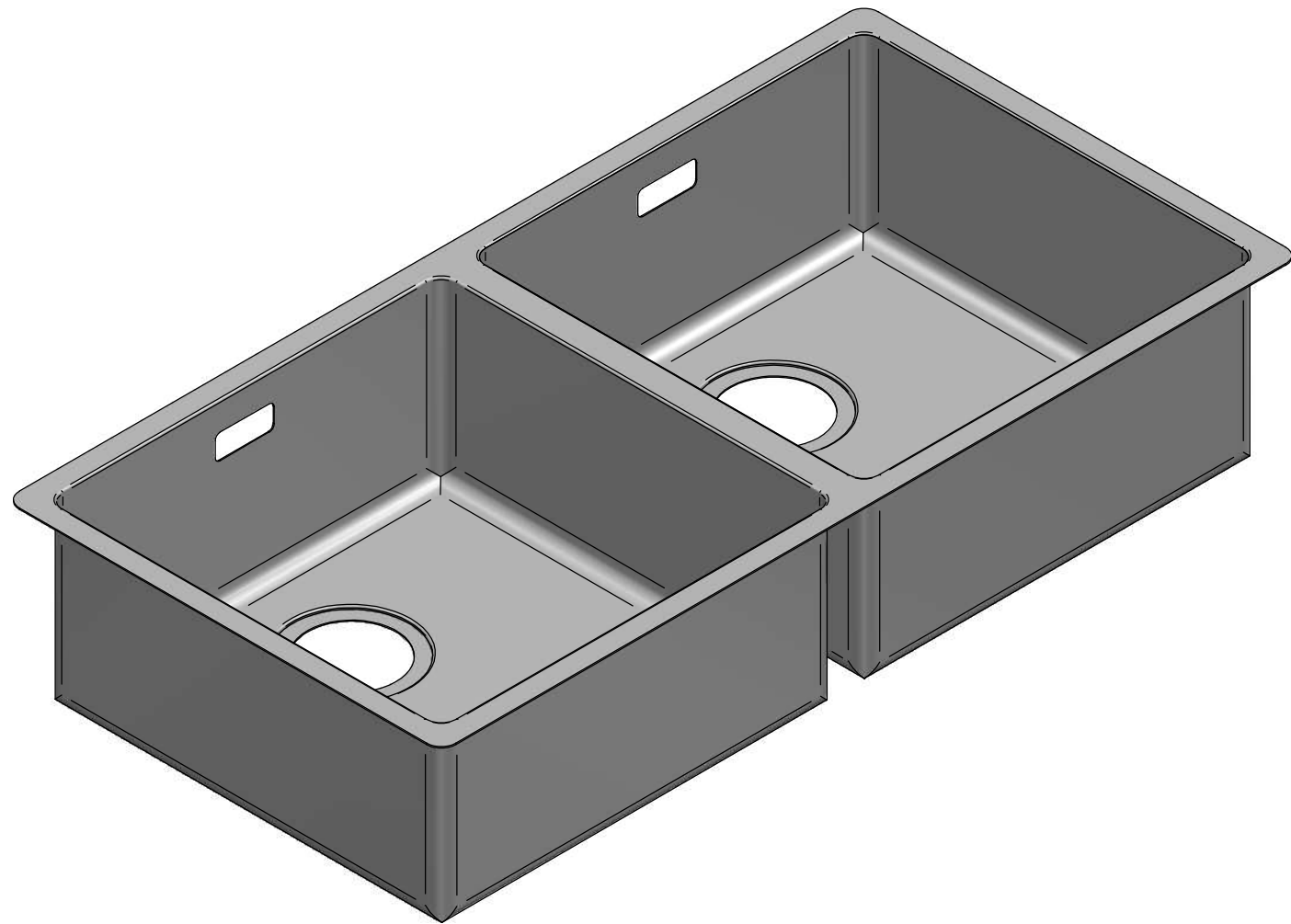

| Part Number | Title | Material | Quantity |
|-------------|----------------------------------|----------------------|----------|
| 228 | DC203R-T9O4, Mercer, 870x440x180 | Stainless Steel, 304 | 1 |

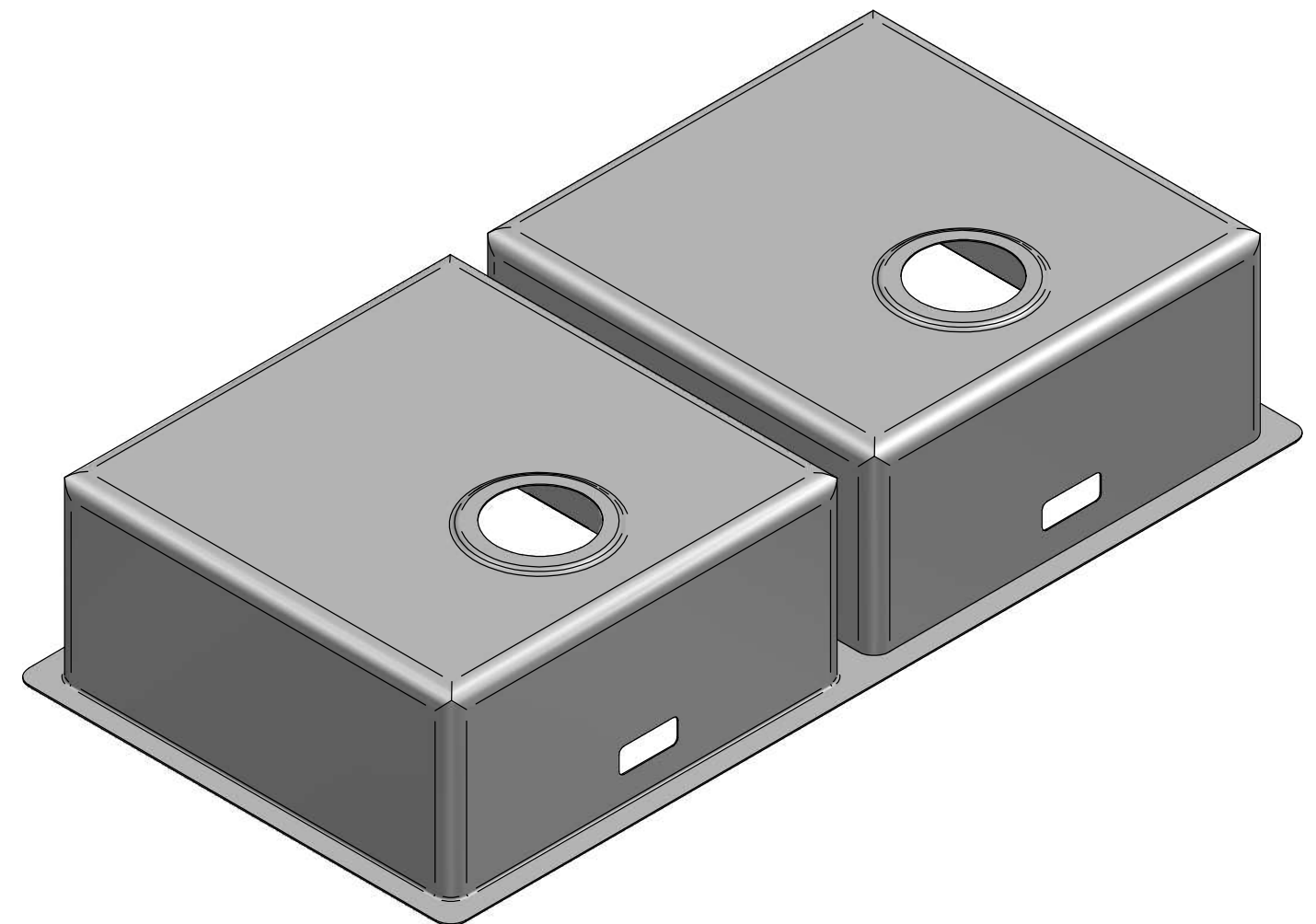

1:5



| | | | | |
|--|--|--------------------------------|------------------------|-------------------------|
|  www.acero.co.nz 45 Lunns Road Middleton Christchurch 8024 New Zealand Phone: 0800 2637237 | Title: DC203-T9O4, Mercer, 870x440x180 | | | Drawn By: MDA-DN |
| | Tolerances: (Unless Stated) | | | Drawn Date: 02 Oct 2017 |
| | X. = ± 2.0 | Material: Stainless Steel, 304 | Third Angle Projection | Checked By: - |
| | X.X = ± 1.0 | Size: 1.0 mm | All Dimensions in mm | Checked Date: - |
| X.XX = ± 0.5 | Finish: - | Mass: 4.08 kg | Rev: 01 | |
| Angles = ± 1.0° | Form: - | Sheet: 1 of 2 | Status: Released | Drawing No: 229 |

NOTE: ALL Dimensions are Reference!

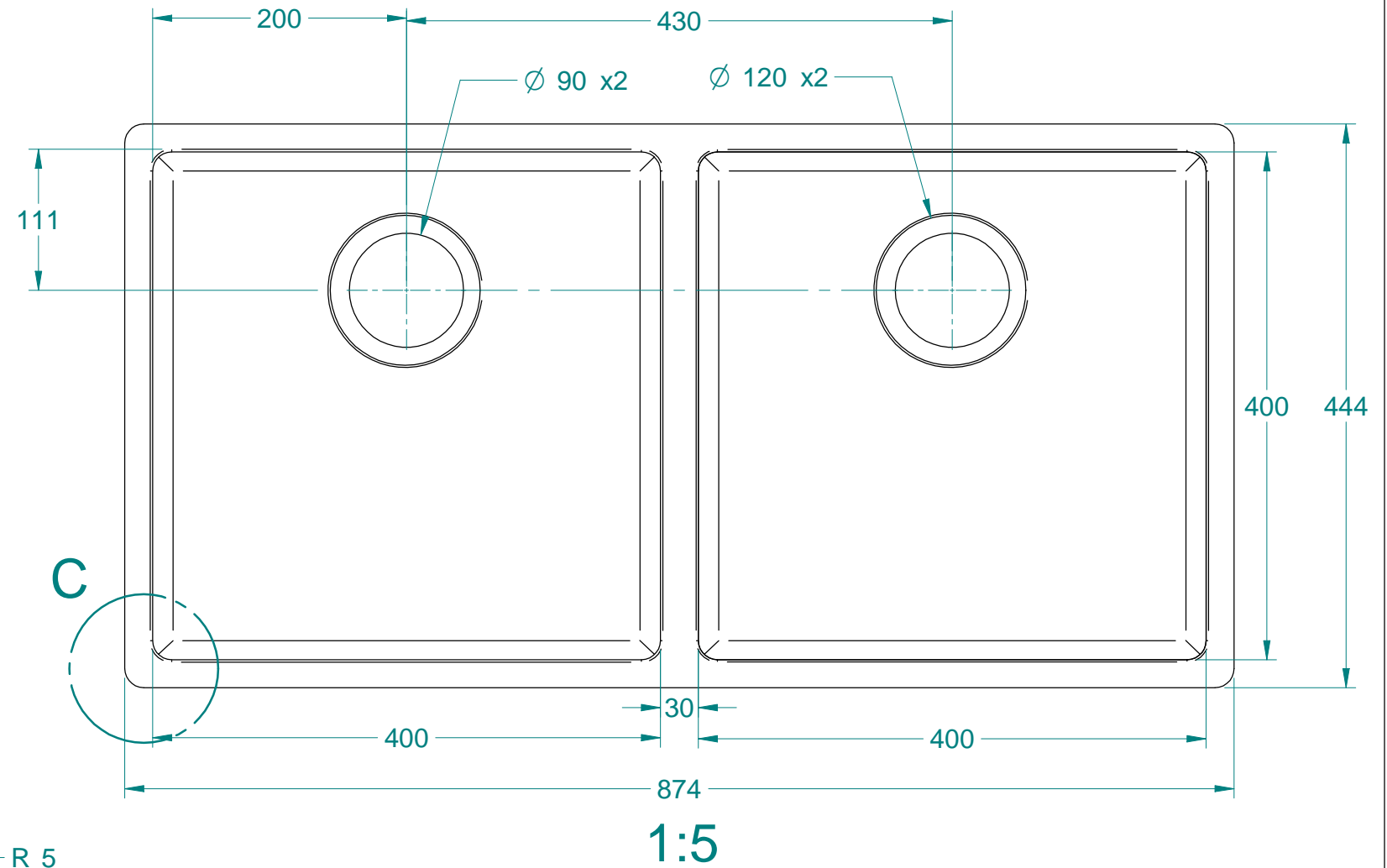
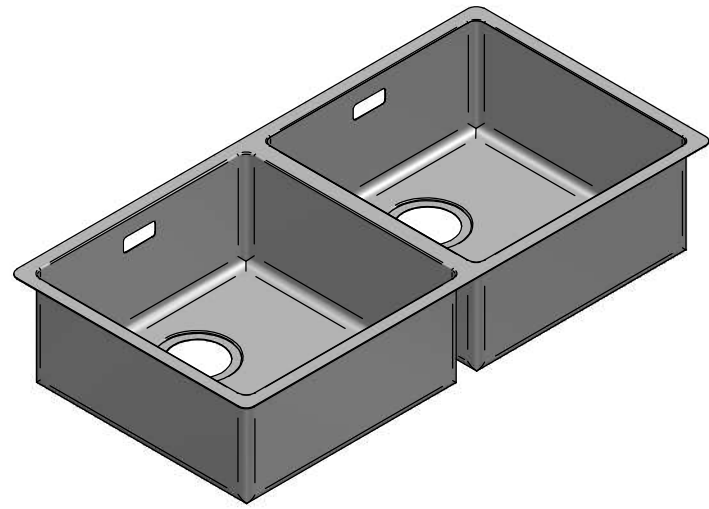

1:10

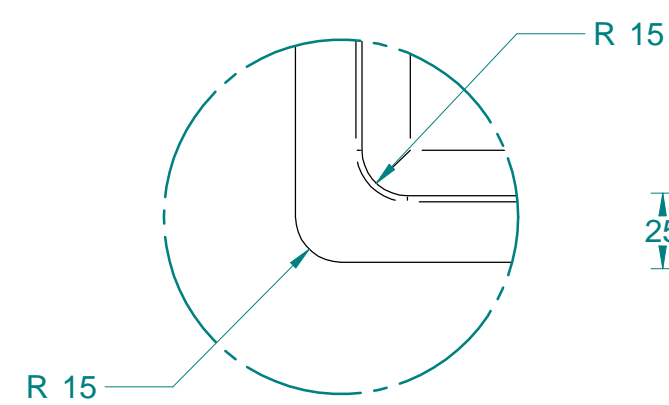

DETAIL C

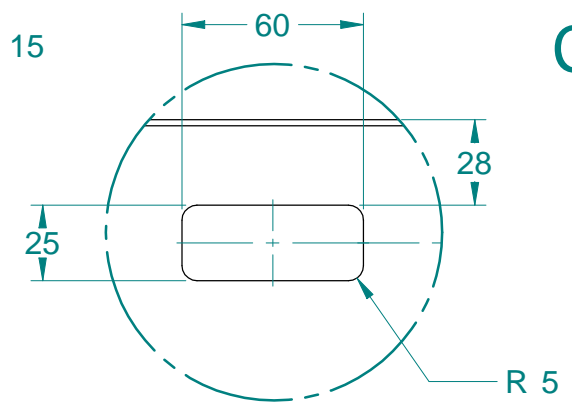

DETAIL B

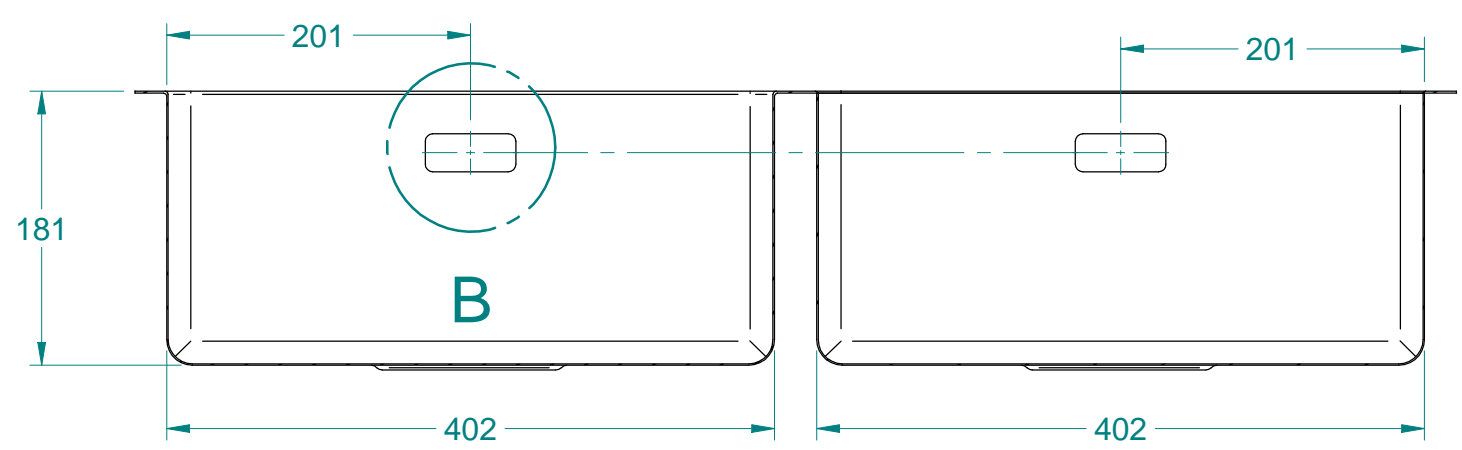
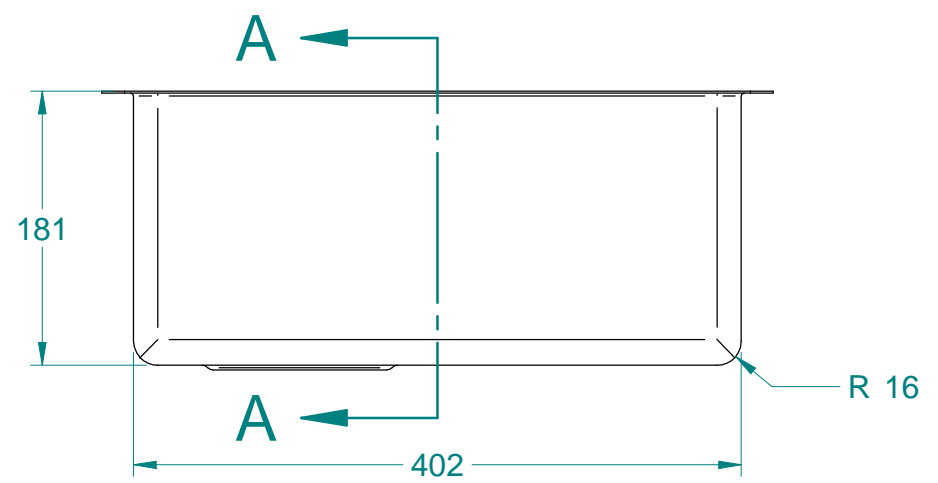

SECTION A-A

NOTE: ALL Dimensions are Reference!

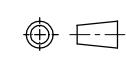
| | | | | |
|---|---|--|---|----------------------------------|
|  www.acero.co.nz 45 Lunns Road Middleton Christchurch 8024 New Zealand Phone: 0800 2637237 | Title: DC203-T9O4, Mercer, 870x440x180 | | | Drawn By: MDA-DN |
| | Tolerances: (Unless Stated) X. = ± 2.0 X.X = ± 1.0 X.XX = ± 0.5 Angles = ± 1.0° | | | Drawn Date: 02 Oct 2017 |
| | Material: Stainless Steel, 304 Size: 1.0 mm Finish: - Form: - | Third Angle Projection All Dimensions in mm Mass: 4.08 kg Sheet: 2 of 2 |  Size: A4 Rev: 01 Status: Released | Checked By: - Checked Date: - |
| | | | | Drawing No: 229 |