

Part Number	Title	Material	Quantity
162	DV103, Mercer, DV, Hartford, 500x400x200	Stainless Steel, 304	1

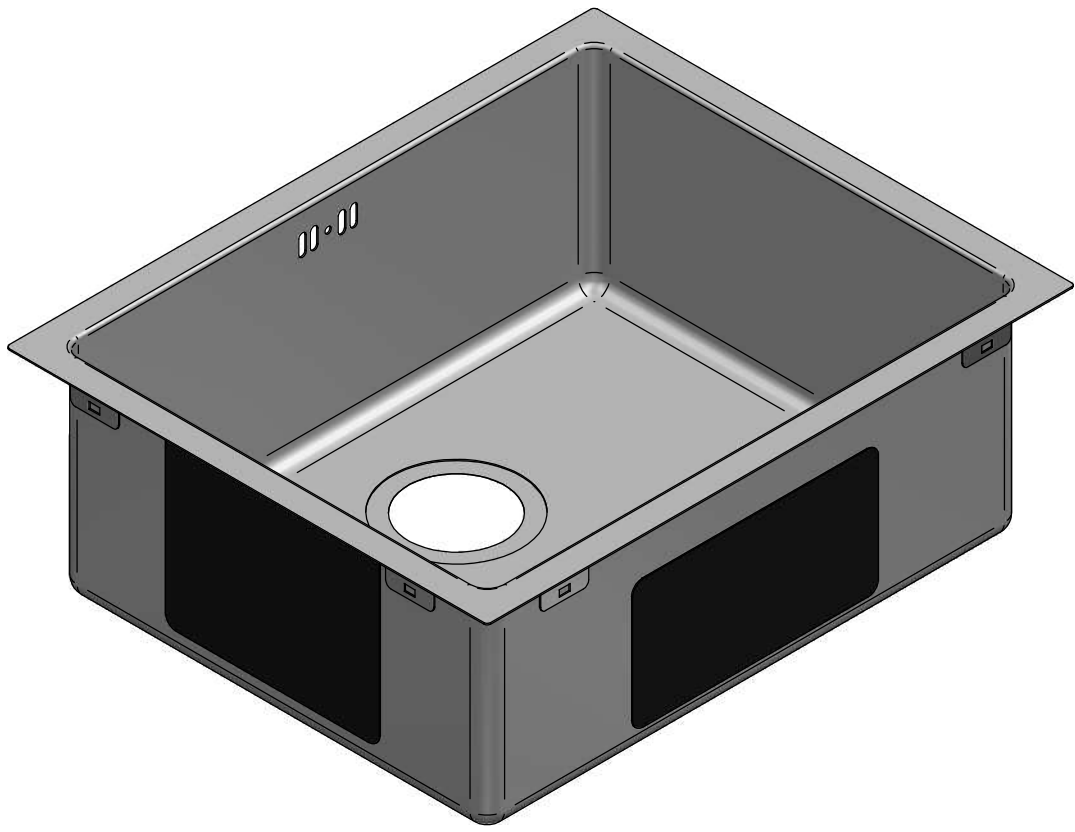

1:5

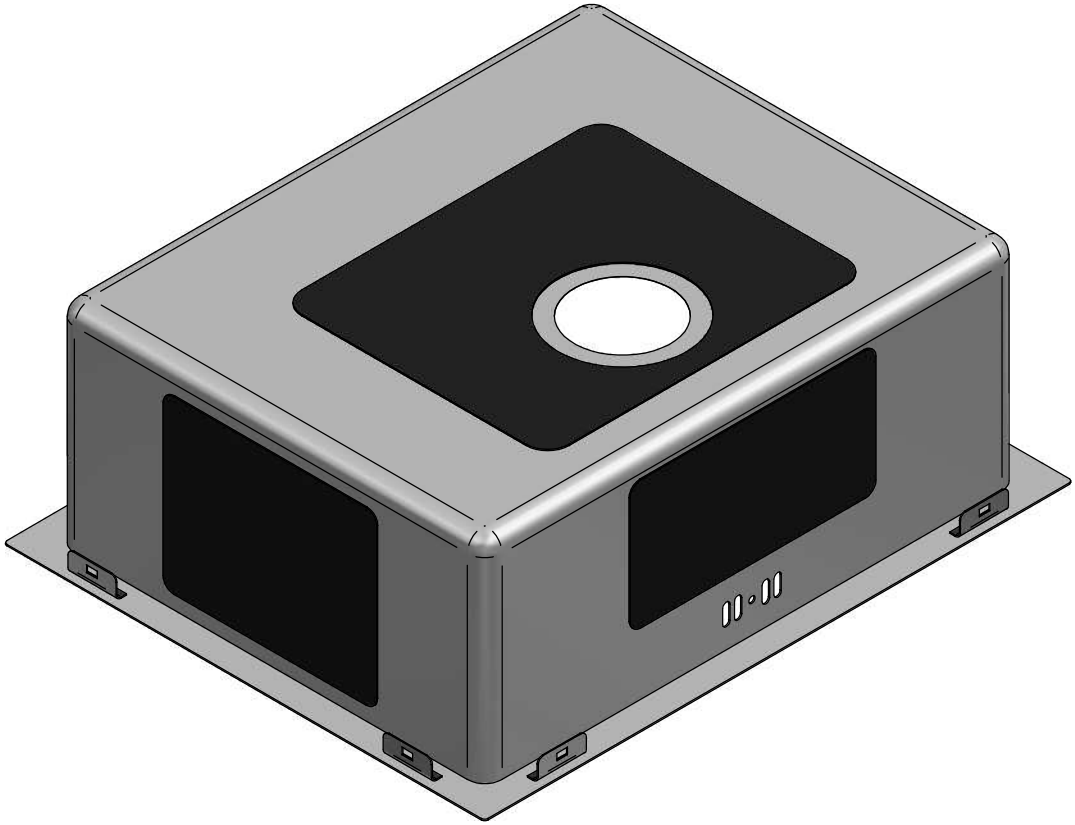

Acero[®]
 www.acero.co.nz
 45 Lunns Road Middleton Christchurch 8024 New Zealand
 Phone: 0800 2637237

Title: DV103, Mercer, Hartford 500x400x200

Tolerances: (Unless Stated)
 X. = ± 10.0
 X.X = ± 6.0
 X.XX = ± 2.0
 Angles = ± 5.0°

Material: Stainless Steel, 304
 Size: 1.2 mm
 Finish: -
 Form: -

Third Angle Projection
 All Dimensions in mm
 Mass: 7.05 kg
 Sheet: 1 of 2

Size: A4
 Rev: 00
 Status: Released

Drawn By: MDA-DN
 Drawn Date: 08 Feb 2018
 Checked By: MDA-JB
 Checked Date: -
 Drawing No: 163

NOTE: ALL Dimensions are Reference!

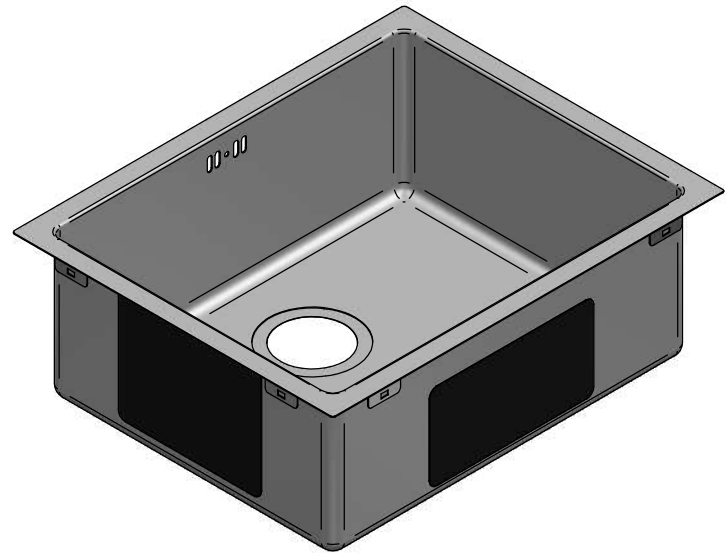

1:7.5

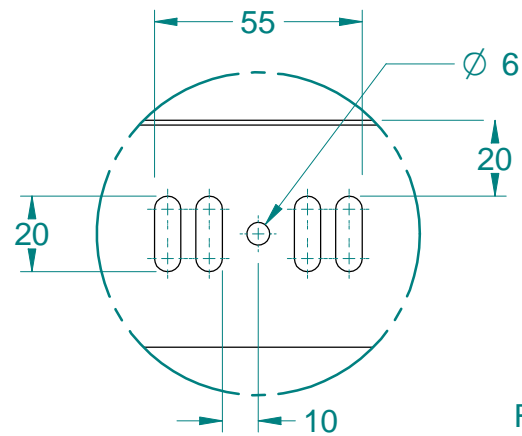

DETAIL A
1:2

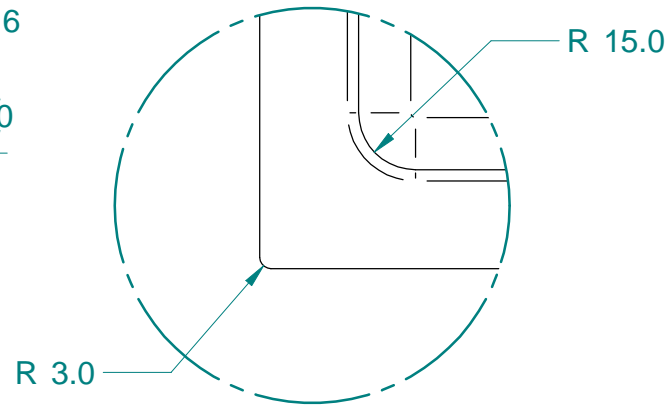

DETAIL B
1:2

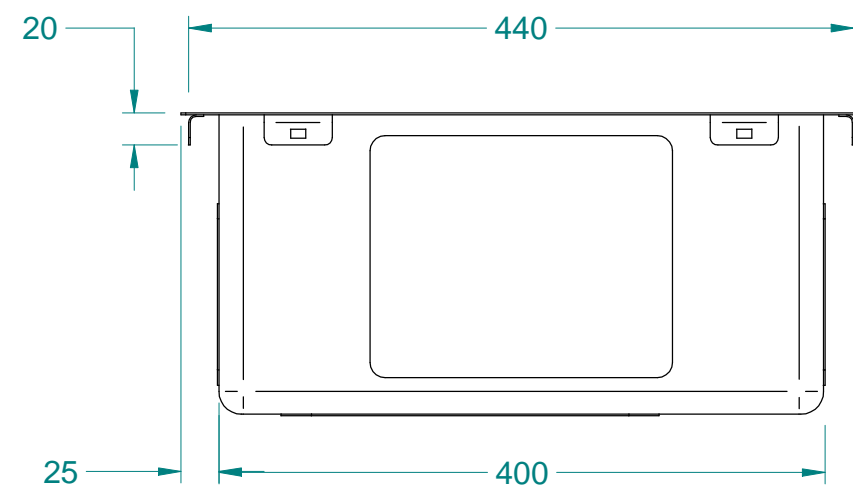
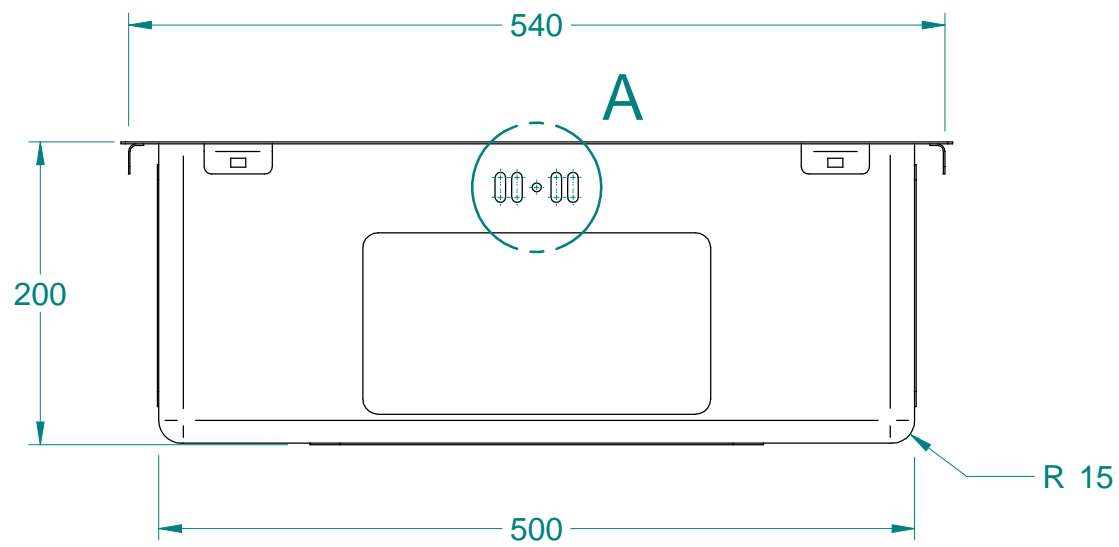
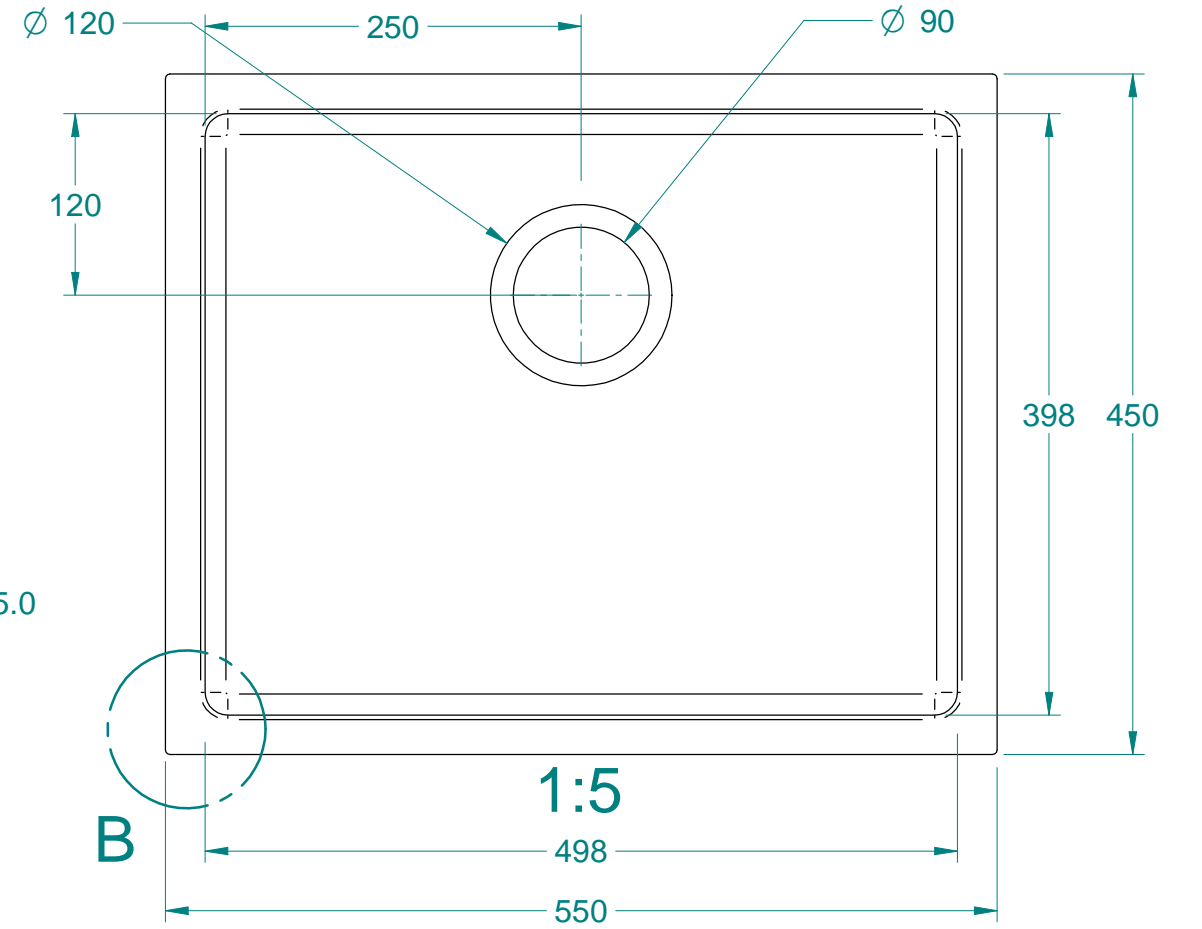

NOTE: ALL Dimensions are Reference!

 www.acero.co.nz 45 Lunns Road Middleton Christchurch 8024 New Zealand Phone: 0800 2637237	Title: DV103, Mercer, Hartford 500x400x200			Drawn By: MDA-DN
	Tolerances: (Unless Stated)			Drawn Date: 08 Feb 2018
	X. = ± 10.0	Material: Stainless Steel, 304	Third Angle Projection	Checked By: MDA-JB
	X.X = ± 6.0	Size: 1.2 mm	All Dimensions in mm	Checked Date: -
X.XX = ± 2.0	Finish: -	Mass: 7.05 kg	Rev: 00	Drawing No: 163
Angles = ± 5.0°	Form: -	Sheet: 2 of 2	Status: Released	